

382-376RH SUMMIT® PRO

MANSFIELD®

Elongated Front, Vitreous China, Two-Piece Toilet

FEATURES

- High performance MagnaFlush™ flushing technology
- SmartFasten™ 3-bolt tank-to-bowl connection
- 1.6 gpf / 6.0 lpf low water consumption
- Elongated front bowl
- PuraClean® easy-to-clean glaze
- Fluidmaster® pilot operated anti-siphon fill valve
- 3" Rigid Flapper flush valve – requires less force to flush, is more consistent and uses a simple universal repair part/seal
- Model 59RH color match, metal trip lever
- 12" rough-in
- 2" glazed trapway
- The Mansfield® limited lifetime warranty on china, Five-year limited warranty on tank trim
- Available in White



MODEL 382-376RH

Toilet seat not included



ELONGATED

COMPONENTS

| MODEL # | DESCRIPTION | CODES/STANDARDS |
|--|--|---|
| 382-376RH | Elongated front, two-piece toilet. Less toilet seat and supply. |  |
| 382 | Elongated front toilet bowl only. Less toilet seat and supply. | |
| 376RH | Tank and cover only, with right hand, front-mount, color match, metal trip lever. Less supply. | |
| TANK TRIM & REPLACEMENT PARTS | | |
| 59RH | Trip lever - color match, metal trip lever, right hand | |
| 2037-1212 | Summit® 1.6 rigid flapper flush valve | |
| 400A | Fluidmaster® anti-siphon pilot fill valve | |
| 2206 | Anti-siphon pilot fill valve (compatible replacement) | |
| 630-0030 | Replacement flush valve seal | |
| 386-LID | Tank lid | |



382-376RH SUMMIT[®] PRO



Elongated Front, Vitreous China, Two-Piece Toilet

SPECIFICATIONS

| MODEL # | DESCRIPTION | CODES/STANDARDS |
|-----------|---|---|
| 382-376RH | Elongated front, (1.6 gpf/6.0 lpf) two-piece toilet |  |

| | |
|----------------------|---------------------------------|
| MATERIAL | Vitreous China |
| WATER PRESSURE RANGE | 20 to 80 PSI |
| FLUSH SYSTEM | MagnaFlush™ flushing technology |
| WATER USAGE | 1.6 gpf / 6.0 lpf |
| WATER SURFACE AREA | 9' X 10' |
| ROUGH-IN | 12' |
| MAP RATING | 1,000 grams |

| | |
|-----------------|--|
| TRAP DIAMETER | 2' |
| TRAP SEAL | 2-1/4' |
| SHIPPING WEIGHT | Model 382 - 50 lbs. (22.6 kg) Model 376RH - 36 lbs. (16.3 kg) |
| WARRANTY | Vitreous China - Limited Lifetime Tank Trim - Limited Five Year |

| TANK OPTIONS | TECHNICAL INFORMATION |
|--------------|--|
| 376 | Variation of model 376RH, with left hand trip lever. |

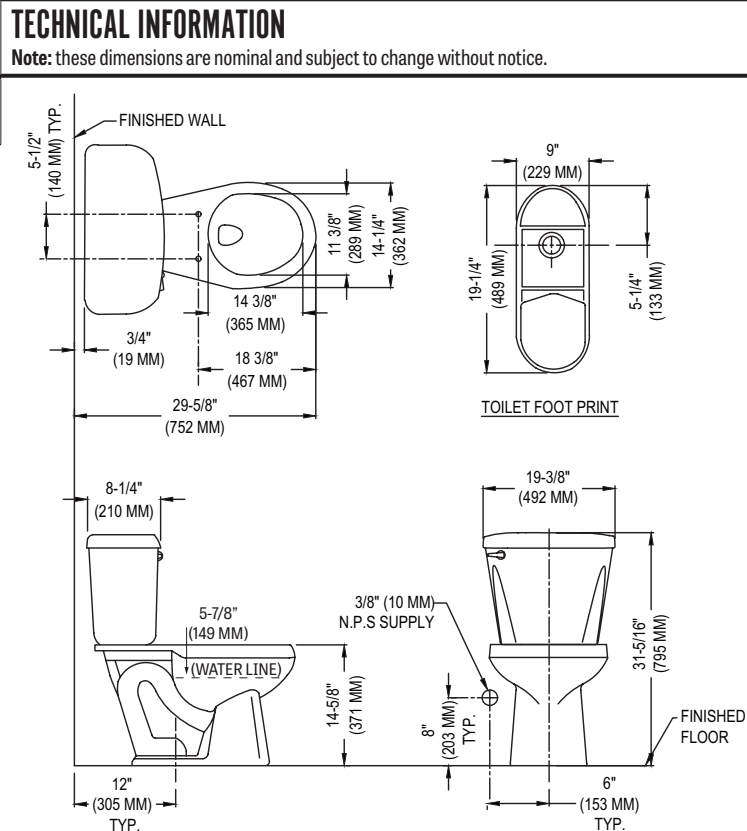

Fixture performance and specifications meet or exceed ASME A112.19.2/CSA B45.1 standards, and other state and local codes.

